

Lab 1A: Microscopy I

A response is required for each item marked: (#__). Your grade for the lab 1 report (1A and 1B combined) will be the fraction of correct responses on a 50 point scale[(# correct/# total) x 50].

Use material from Section 18.1 of your text to label the condenser, objective, and ocular lenses in the diagram of the compound light microscope in Figure 1. Describe the function of each lens in producing the magnified image of a specimen:

Condenser Lens: (#4)

Objective Lens: (#5)

Ocular Lens: (#6)

The maximum useful magnification that can be obtained with a microscope is limited by its maximum resolving power. Based on your reading from the text, define resolution in your own words. What unit is used to describe the resolution of a microscope? (#7)

How does that unit compare to that used to describe the resolution for a computer screen? (#8)

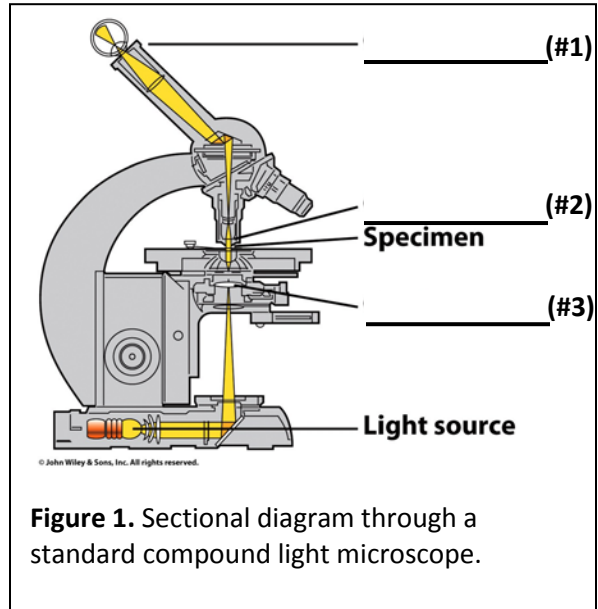

Figure 1. Sectional diagram through a standard compound light microscope.

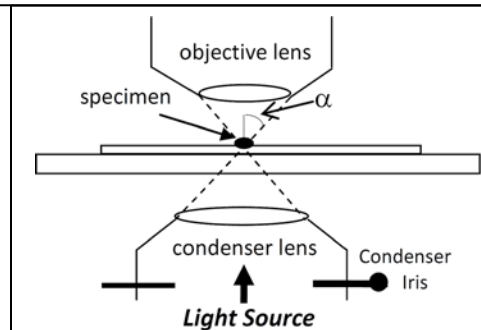

Figure 2. Light Path between the condenser and objective lens.

λ = light wavelength
 n = refractive index of medium between specimen and lenses (1 for air; 1.5 for oil)
 α = $\frac{1}{2}$ cone angle of light entering objective from specimen
 N.A. (numerical aperture) = $n \sin \alpha$

The following equation can be used to determine the resolving power of a microscope:

$$\text{Resolving Power (d)} = \frac{0.61 \lambda}{n \sin \alpha} \quad (\text{denominator} = \text{N.A. of objective lens})$$

Based on this equation, what features of a microscope could be manipulated to increase resolution? (#9)

What effect will opening the condenser iris have on the cone angle of light entering the specimen? How will this affect resolution? (#10)

Use this formula and your reading from Section 18.2 to explain how the electron microscope is able to provide ~200-fold higher resolution (1.5 nm), and thus higher useful magnification, than a light microscope. (#11)

Lab Exercise:

Familiarize Yourself with Your Compound Microscope

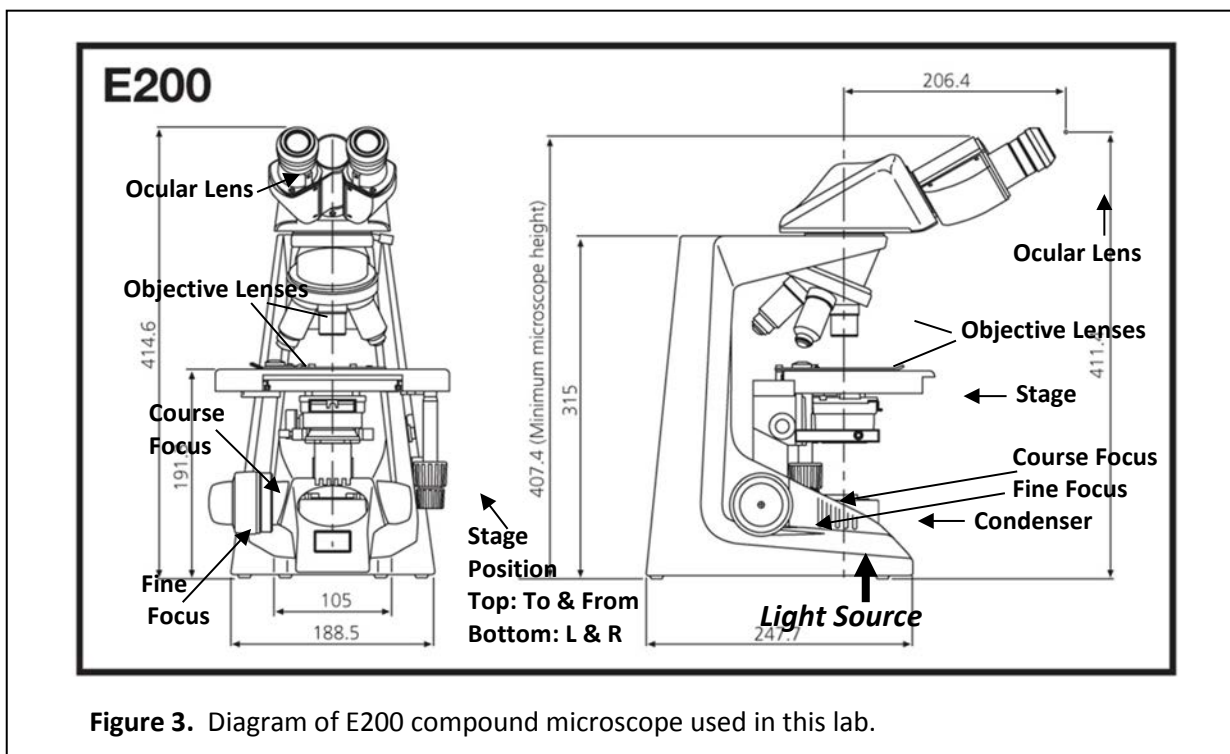

Each pair of lab partners will share a Nikon E200 compound light microscope equipped with a 10x ocular and four objective lenses. Identify each component labeled in the diagram of the E200 microscope in Figure 3.



Figure 4. Photograph of objective lenses on your E200 microscope.

The specifications for each objective lens are etched along its side as shown in Figure 4). Each of the lenses is an achromatic plan objective, meaning they have been corrected for imperfections in color and curvature across the field of view. Enter the values for Magnification, Numerical Aperture (N.A.) and Working Distance (WD) for each lens in Table

1. Then use this information and the formula for Resolving Power (d) on pg. 1 to calculate the final magnification and d for each lens. (Use the N.A. for the lens as the denominator of the equation and a λ of 500 nm.) The Working Distance and Depth of Field give information about how easy the lens will be to work with. Working Distance is the distance between the top of your specimen and the bottom of the lens when the specimen is in focus. The greater this distance, the less likely you will damage your specimen while attempting to focus. The Depth of Field and Diameter of Field for each lens also affect ease of focus. Depth of Field is the thickness of a specimen that will be in focus at a given focal setting and is inversely proportional to the N.A. for a lens. The Depth of Field for each lens is not recorded on your objectives but can be obtained from the Nikon website linked on the course webpage. Diameter of Field is the size of the horizontal region of the specimen that can be visualized in a single field of magnification and is inversely proportional to the magnification of the lens. Because these two factors and WD all decrease as the power of the objective lens increases, it is wise to always begin any microscopic examination at the lowest power available and work your way up to the final required resolution.

Table 1. Objective Lens Specifications

Objective Lens	Final Mag	N.A.	d	WD	Depth of Field	*
CFI E Plan Achromat 4x					90.0 μm	(#12)
CFI E Plan Achromat 10x					14.4 μm	(#13)
CFI E Plan Achromat 40x					1.84 μm	(#14)
CFI E Plan Achromat 100x Oil					0.65 μm	(#15)

*Depth of Field Calculator available on Nikon Website

Hypothesis Forming

Based on the specifications of the four objective lenses available to you and the typical diameter of the cellular structures listed below, determine the **minimum** power lens required to resolve it (observe as a distinct structure within a cell). If none of the lenses has sufficient resolving power, write *None*.

Minimal Objective Lens Required to Resolve Cellular Structures

<u>Cellular Structures</u>	<u>Diameter</u>	<u>Minimal Objective Required</u>
Nucleus	10 μm	(#16)
Mitochondria	1-4 μm	(#17)
Golgi Cisternae	0.5-1 μm	(#18)
Ribosome	20 nm	(#19)
Microfilament (actin filament)	8 nm	(#20)
Succinate Dehydrogenase	0.4 nm	(#21)

Which of the structures would not be resolved by the highest power lens available to you but might be resolved by electron microscopy? **(#22)**

Specimen Preparation

Today you will prepare wet mounts of onion epidermal cells and squamous epithelial cells from your own cheeks. Each specimen will then be examined by light microscopy, both with and without staining. You will also prepare fixed *Drosophila* embryos for fluorescence microscopy in the next lab session.

The following reagents and supplies can be found on the:

Lab Reagent Bench

- 1) 1 apple juice plate of *Drosophila* embryos
- 2) 1 Onion section
- 3) 1 tube Bleach (**labeled Bleach**)
- 4) 1 Eppendorf tube filled with Heptane (**labeled H**)
- 5) 1 Eppendorf tube filled with MeOH/EGTA (**labeled Me**)

Your Benchtop

- 1) package Cotton swabs
- 2) 1 Iodine Stain in dropper bottle
- 3) 1 small paint brush
- 4) H₂O wash bottle
- 5) stack of paper towels for blotting
- 6) Eppendorf rack
- 7) Lab Bench Box containing:

Forceps
box microscope slides; box coverslips
minisieve

Specimen Preparation for Fluorescence Microscopy in Lab 1B (next week)

Before you begin your specimen preparations for light microscopy, you will collect *Drosophila* embryos from the apple juice agar plate you got from the Lab Reagent bench and fix them for use in the fluorescence microscopy exercises of the next lab. The fixation will stop the development of the embryo at a specific stage, stabilize the subcellular structures, and make the embryos permeable to fluorescent dyes and fluorescently labeled antibodies.

Fixation Protocol (Watch the Demo Before Beginning)

1. Before you harvest your embryos from the surface of the apple juice plate, prepare a tube of fixative that you will transfer your embryos to after removing their outer shells (chorion). Add 500 μ l MeOH from the tube **labeled Me** to the tube of heptane (**labeled Hep**).
2. Use the small brush and H₂O from your H₂O wash bottle at your bench to loosen the embryos from the surface of the apple juice plate you got from the Lab Reagent bench.
3. Pour the suspension of embryos into the small sieve sitting at your bench. Be careful not to overflow; pour a little at a time. Continue to rinse the plate with H₂O and pour the suspension into the sieve until the bulk of the embryos have been transferred to the sieve.
4. Use the H₂O bottle to rinse the yeast paste (food for adult parents of the embryos) from the sieve. Place the sieve on a dry surface of a stack of paper towels to blot away excess H₂O.
5. Place the sieve with embryos in the petri dish cover. Use a Pasteur pipette and bulb to transfer 50% Bleach into the sieve. Allow the bleach to fill the petri dish cover half-way. Gently rotate the petri dish cover to keep the embryos moving around in the Bleach for about 1 minute.
6. Transfer the sieve to a dry region of the stack of paper towels and immediately rinse with H₂O. Let the sieve fill with H₂O, and then move it to a new dry region of the paper towel stack. Repeat this procedure about 4 times, each time moving to a new dry area of the paper towel stack. The embryos will tend to aggregate together and flow to the center of the sieve.
7. Use the small paintbrush to lift the embryos from the surface of the sieve and transfer them to tube containing the heptane-MeOH mix from Step 1 above. Cap the tube and shake vigorously. ***This step dissolves the waxy coat (vitelline membrane) surrounding the embryos.***
8. Place the tube of embryos in the heptane-MeOH mix in an eppendorf tube rack and allow the embryos to sink to the bottom of the tube. The heptane and MeOH will also separate into distinct phases. ***Only the embryos with a dissolved vitelline membrane will sink to the bottom of the tube.***
9. Use a Pasteur pipette to remove the upper heptane layer and part of the lower MeOH layer from the tube, being careful not to remove any of the embryos at the bottom of the tube. It is ok to leave $\sim \frac{1}{4}$ " of MeOH in the tube.
9. Fill the tube with MeOH from the tube labeled **Me**. Again place the tube in an Eppendorf rack and allow the embryos to settle. Remove all but $\sim \frac{1}{4}$ " of MeOH from the tube, before replacing it with fresh MeOH. Place this tube on the rotator on the middle lab bench. The embryos must be incubated with MeOH for at least one hour to permanently fix their internal structures. Your tube of fixed embryos will sitting at your bench for the immunostaining procedure in the next lab period. **Be sure to label the tube with your bench #, so it can be returned to you in the next lab period.**

Questions:

1. What would cause the embryos to aggregate together during the wash with H₂O in step #5? Based on this behavior, do you think the vitelline membrane has polar or non-polar character? **(#23)**

2. What would cause the embryos to immediately come loose from the paintbrush and disperse in the heptane phase in step #6? **(#24)**

Specimen Preparation for Light Microscopy

Wet Mount of Onion Epidermis

1. Place a drop (about 20 μ l) of water in the center of one microscope slide and a drop of Iodine Stain in the center of a second microscope slide.
2. Use pointed forceps to remove two thin strips from the outer (concave) layer of the onion section.
3. Place one onion strip in the drop of water on the microscope slide and the second one in the drop of Iodine solution on the second microscope slide.
4. Lower a coverslip over each specimen, being careful not to trap air bubbles between the coverslip and slide.

Wet Mount of Squamous Epithelial Cheek Cells

1. Place a drop (about 20 μ l) of water in the center of one microscope slide and a drop of Iodine Solution in the center of a second microscope slide.
2. Use a cotton swab to swipe the inner surface of your cheek (inside your mouth) to remove squamous epithelial cells.
3. Twirl the cotton swab containing squamous epithelial cells in the drop of water on one microscope slide.
4. Obtain a second swipe of squamous epithelial cells and twirl it in the drop of Iodine solution on the second microscope slide.
5. Lower a coverslip over each specimen, being careful not to trap air bubbles between the coverslip and slide.

Specimen Examination by Light Microscopy

1. Place the Iodine-stained onion epidermis specimen on the microscope stage, and use the lowest power dry objective lens (4x) and the course focus knob to bring it into focus. You may need to use the stage positioning knob to search for your specimen as movement of an unfocused image. Once you are able to detect the out-of-focus image, use the fine focus knob to bring your specimen into full focus. In the space below, make a sketch of what YOU see (not what you were supposed to see). **(#25)**

2. Now rotate the objective wheel to the next higher power objective (10x) into the light path and use the fine focus knob to bring your specimen into focus. Adjust the opening of the condenser iris to give optimal clarity of the nucleus. In the space below, sketch what YOU see with this objective. **(#26)**

3. Using the 40x objective, make adjustments with your fine focus knob and the condenser iris to get the clearest image possible. Sketch what YOU are able to see with the 40x objective. **(#27)**

4. How would you compare the 4x and 10x objectives in terms of differences in magnification and resolution? (Can YOU see the perimeter of the nucleus with both objectives or only with one?) **(#28)**

How would you compare the 10x and 40x objectives? (Can YOU see the perimeter of the nucleus with both objectives or only with one?) **(#29)**

5. Use each the 4x, 10x, and 40x objectives to view the unstained onion epidermis. Which is the lowest power objective needed to clearly see the nucleus and its perimeter in this specimen? **(#30)**

Make adjustments to the condenser iris opening to achieve optimal clarity. How does this adjustment compare to the one that gives the best clarity of the stained specimen (more or less open)? **(#31)**

6. Repeat the exercise above with the slides of stained and unstained squamous cheek cells. Which is the lowest power objective required to see the nucleus and resolve its perimeter in this stained specimen? **(#32)**

How do adjustments to the condenser iris affect visibility of each specimen? **(#33)**

7. How do your predictions about resolution on page 3 compare to the actual results observed? How do you account for any discrepancy? **(#34)**

Lab 1B: Microscopy II- Fluorescence Microscopy

A response is required for each item marked: (#___). Your grade for the 1A/1B lab report will be the fraction of correct responses on a 50 point scale[(# correct/# total) x 50].

Pages 719-722 of your text describe a type of light microscopy (fluorescence microscopy) in which a specific molecule within a specimen is detected through a fluorescent tag. The specificity of fluorescent microscopy is achieved through illumination of the specimen with light of a defined wavelength designed to excite the fluorescent tag. The primary benefit of fluorescence microscopy is the specificity it provides, but the intensity of the fluorescent signal also enhances the sensitivity of detection.

Fluorescent molecules absorb energy from light of a short, high energy wavelength and emit a portion of that energy at a longer wavelength of less energy. Some fluorescent molecules that are commonly used by cell biologists are the DNA-specific DAPI stain (absorbs at 358 nm; emits at 461 nm), fluorescein (absorbs at 494 nm; emits at 521 nm), and texas red (absorbs at 589 nm; emits at 615 nm).

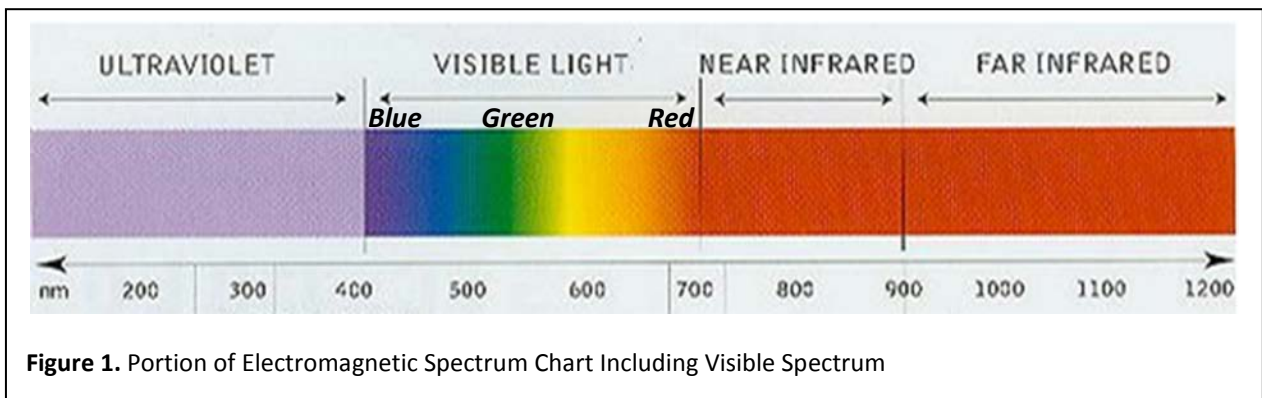

Based on the electromagnetic spectrum chart in Figure 1:

- A) What color will a DAPI-stained molecule appear? (#35)
- B) What color will a fluorescein-labeled molecule appear? (#36)
- C) What color will a texas red-labeled molecule appear? (#37)

The fluorescence microscope achieves this specificity through a set of filters that selectively allow the absorption wavelength of light which excites the fluorescent tag to reach the specimen and the emission wavelength for that tag to reach the ocular lens. The pair of filters is arranged in a filter cube such that a light path from a high energy mercury light source passes through a selective **excitation filter** before being diffracted off a dichromatic mirror and reaching the specimen. The light diffracted from the specimen then must pass through a **barrier or emission filter**, selectively allowing only the emission wavelength of the fluorescent tag to reach the ocular lens.

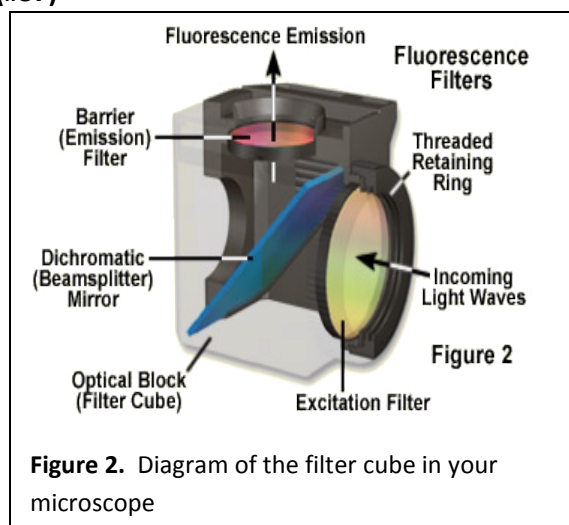

Methods for labeling molecules with fluorescent tags

Four commonly used methods for attaching a fluorescent tag to a molecule of interest for fluorescence microscopy are described below. Methods 1, 2, and 4 will be used in today's exercise.

1) Direct attachment through non-covalent binding of fluorescent stain. This type of labeling is done through fluorescent molecules that display natural binding specificity for a molecule of interest. Although this method is less universally useful, it is used routinely to label DNA through DAPI staining. DAPI fluoresces blue only when bound to the minor groove of DNA.

2) Immunofluorescence: indirect attachment through a fluorescently labeled antibody. This commonly used method uses an antibody to target a fluorescent tag to a protein of interest. Antibodies are produced by cells of vertebrate immune systems to specifically recognize and bring about the destruction of foreign molecules. (See pg. 684 of text) Cell biologists make use of antibody-specificity as a means for targeting a fluorescent tag to the protein it recognizes. Figure 3 shows that the fluorescent tag can either be **directly (A)** attached to the antibody recognizing the protein or interest or it can be **indirectly (B)** attached to it through a fluorescently tagged secondary antibody that recognizes that antibody (called the primary antibody). The indirect method B is more commonly used, because fluorescently labeled secondary antibodies that recognize any primary antibody produced in a particular vertebrate (e.g., mouse or rabbit) are widely available through commercial sources. The wide availability of these secondary antibodies makes this method more convenient, in practice.

3) Direct attachment through covalent linkage. Although it requires more work, it is also possible to chemically link a fluorescent tag to any protein of interest. Fluorescent molecules with chemically reactive side chains are commercially available for catalyzing the covalent linkage of a fluorescent tag to a purified protein in a test tube reaction. The *in vitro* labeled protein must then be injected into a living cell, in which it can be monitored by fluorescence microscopy.

4) In vivo expression of GFP-fusion proteins. This more recently developed method also allows the behavior of a labeled protein to be monitored in a living cell. However, this method allows the cell to do the work of producing the fluorescently labeled protein. This is done by producing a recombinant gene in which the gene encoding the protein of interest is fused to a gene for the naturally fluorescing Green Fluorescent Protein (GFP) from the jellyfish *Aequorea victoria*. The recombinant gene is then

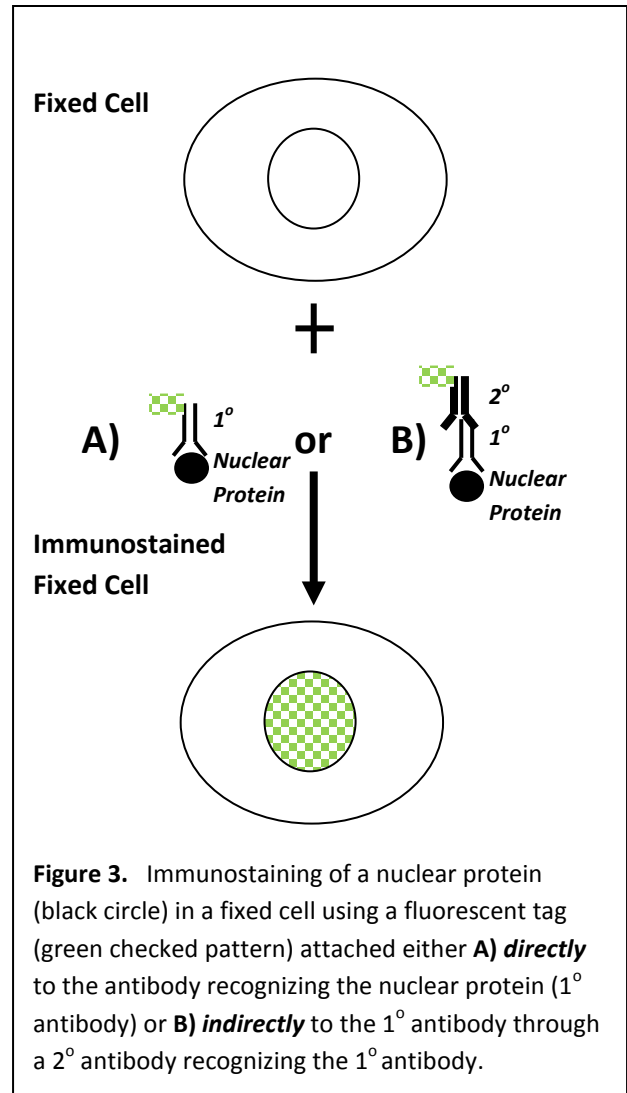

Figure 3. Immunostaining of a nuclear protein (black circle) in a fixed cell using a fluorescent tag (green checked pattern) attached either **A) directly** to the antibody recognizing the nuclear protein (1° antibody) or **B) indirectly** to the 1° antibody through a 2° antibody recognizing the 1° antibody.

transferred into the genome of a living organism, where it is transcribed and translated into a GFP-tagged version of the protein of interest.

Methods 1 and 2 require that the cells be treated with a fixative before staining. Methods 3 or 4 require a living specimen. The researcher chooses which of these methods to use on the basis of what he/she wants to learn from an experiment and the time and cost required. In today's exercise we will use Methods 1, 2 and 4. Method 3 requires more time than is available in the lab period.

Specimen Preparation

You will use the *Drosophila* embryos you fixed in the previous exercise for Methods 1 and 2. The embryos will be immunostained with two different antibodies. One antibody recognizes the histone H1 protein associated with DNA in all cells, at all stages of embryonic development. The second antibody recognizes a neuronal protein, which is only expressed in neuronal tissues of later staged embryos. We will use the indirect method for targeting the fluorescent tag to these antibodies through a secondary antibody (Figure 3B). The antibodies recognizing histone H1 and the neuronal protein will be the primary (1^o) antibodies in our protocol. The incubation with each primary antibody will be followed by a wash and then a second incubation with a fluorescently labeled secondary (2^o) antibody. Both primary antibodies were produced in mice, which will each be combined with a secondary antibody with specificity for an invariant domain found in all IgG class antibodies produced in mice (anti-mouse 2^o antibody). The embryos are then again washed after the incubation with the fluorescently labeled secondary antibody and mounted in a medium containing the fluorescent DNA stain, DAPI. This procedure will, therefore, provide an example of both Methods 1 and 2.

You will also prepare specimens of *Drosophila* embryos in which Method 4 has been used to label the histone protein with a fluorescent tag. Because the immunostaining protocol has several long incubation steps, you must begin that protocol first. Then during the 45 minute 1^o antibody incubation step, you will collect embryos from a stock expressing a GFP-tagged histone and from a wild type stock and prepare them for fluorescence microscopy of the GFP-tagged protein in a living embryo.

The following reagents should be sitting on your benchtop:

On ice

- 1) 1 tube mouse anti-histone 1^o antibody (**labeled H1**)
- 2) 1 tube mouse anti-neuronal 1^o antibody (**labeled N**)
- 3) 2 tubes fluorescein-labeled anti-mouse 2^o (**labeled 2^o**)

Room temp

- 4) your tube of fixed *Drosophila* embryos (**labeled with your Bench #**)
- 5) apple juice plate of embryos from GFP-tagged histone-expressing stock (**labeled GFP-his**)
- 6) apple juice plate of embryos from wild type wt stock (**labeled wt**)
- 7) tube of 50% MeOH (**labeled 50% Me**)
- 8) tube of 25% MeOH (**labeled 25% Me**)
- 9) tube of Wash Buffer (**labeled Wash**)
- 10) tube of embryo mounting medium w/ DAPI stain (**labeled Mount**)
- 11) tube of Halocarbon oil (**labeled Halo**)
- 12) paper towels (for blotting)
- 13) small paint brush

- 14) H₂O squirt bottle
- 15) Eppendorf tubes
- 16) Pasteur pipettes, yellow and blue tips
- 17) in Lab Bench Box:
 - Pasteur pipette bulbs
 - box microscope slides
 - box coverslips
 - minisieve
 - timer

Drosophila Embryo Immunostaining Protocol (Methods 1 and 2)

Pre-1° Wash:

1. The *Drosophila* embryos you fixed during the previous lab period must be rehydrated before they can be incubated with antibody in an aqueous solution. This must be done gradually to prevent the embryos from undergoing osmotic shock and bursting. To rehydrate the embryos, place the tube of embryos in an Eppendorf rack and allow the embryos to sink to the bottom of the tube. Then use a Pasteur pipette to carefully remove the MeOH from the tube, leaving ~1/4" of liquid to avoid accidentally removing a portion of the embryos during pipetting. Refill the tube with **50% MeOH**. Manually invert the tube for ~ 1 minute, then allow the embryos to settle in the tube before removing all but ~1/4" of liquid. Now refill the tube with **25% MeOH** and repeat the process before refilling the tube with **Wash Buffer**.
2. You will now split the embryos into two separate Eppendorf tubes for incubations with the two different 1° antibodies. Draw some Wash Buffer into your Pasteur pipette to wet its inner surface before using the same pipette to draw up about half of the embryos into the pipette and transfer them to a second Eppendorf tube. Label one tube H1 (for anti-histone H1 1° antibody) and the second one N (for anti-neuronal protein 1° antibody). Allow the embryos to sink in both tubes and remove all but ~1/8" Wash Buffer from above the embryos in each.

1° Antibody Incubation:

2. Retrieve one tube of **anti-histone 1° (labeled H1)** and one tube of **anti -neuronal marker 1° antibody (labeled N)** from the ice bucket on your bench.
3. Fill the tube labeled H1 with anti-histone 1° antibody and the tube labeled N with the anti-neuronal marker 1° antibody. You can use a Pasteur pipette to transfer the antibodies, since the volume has been pre-measured with a correct concentration of each antibody.
4. Place the tubes on the rotator on the middle lab bench and rotate for 45 min.

During the 1° antibody incubation, go to the protocol for Live Imaging of GFP-tagged Histones in Drosophila Embryos on the following page. Set your timer for 45 min, so you will know when to return to the immunostaining protocol at the Post-1° Wash step below.

Post-1° Wash:

5. Allow the embryos to settle in the tube. Remove the 1° antibody solution from above them with a Pasteur pipette (*Discard in Liquid Waste Container*) and add fresh Wash Buffer. As always, avoid removal of embryos while pipetting by leaving ~1/8" buffer zone. Invert the tube several times before

allowing the embryos to sink. Replace with fresh Wash Buffer. Repeat the procedure one more time.

6. After the third wash, use a “yellow” tip on your P-200 to remove the remaining Wash Buffer.

2° Antibody Incubation:

7. Fill each tube with fluorescein-labeled **anti-mouse 2° antibody (2 tubes labeled 2°)**. You can use a Pasteur pipette to do this, since the volume has been pre-measured.
8. Place the tubes on the rotator on the middle lab bench and rotate for 45 min. **Set your timer for 45 min, when you will return to the Post-2° Wash step of the Embryo Immunostaining Protocol.**

Post-2° Wash:

9. Allow the embryos to settle in the tube. Remove the 1° antibody solution from above them with a Pasteur pipette (*Discard in Liquid Waste Container*) and add fresh Wash Buffer. Invert the tube several times before allowing the embryos to resettle. Replace with fresh Wash Buffer. Repeat the procedure one more time.
10. After the third wash, use a “yellow” tip on your P-200 to remove the remaining Wash Buffer.

Embryo Mounting:

11. Use a razor blade to make a cut ~1/4” from the opening of a blue tip to enlarge the opening. Use this tip on your P-1000 to transfer 100 µl mounting medium + DAPI stain to the embryos in each tube. The embryos will tend to rise to the top of the mounting medium.
12. Place two clean microscope slides on your benchtop. Label one **Histone** and the other **Neuron**.
13. Use the enlarged “blue” tip from step 11 with your P-1000 on the 100µl setting to draw the embryos that have risen to the top of the mounting medium into the tip and transfer them onto the correctly labeled microscope slide. Avoid jamming the tip all the way to the bottom of the tube where embryos may have settled.
14. Use a P-200 to remove any air bubbles in the mounting medium, before placing a coverslip on top of it. The mounting medium will gradually spread throughout the space between the slide and coverslip. You can gently tap down on the coverslip, but be careful not to slide the coverslip across the surface of the microscope slide. This will cause the embryos to shear apart.
15. The slides are now ready to view! **See Specimen Examination by Fluorescence Microscopy instructions below.**

Live Imaging of GFP-Tagged Histone-Expressing Embryos (Method 4)

Each bench will collect embryos from two stocks; one group collects from a stock expressing a gene for GFP-tagged histone and the other group collects from a stock lacking this gene. The embryos from these stocks will be mounted in a way that will preserve embryonic viability. Fluorescence microscopy will then be used to observe the live dynamics of the GFP-tagged histone in the chromosomes of these embryos. You will collect embryos from each stock at two different developmental stages (if possible). An overnight collection of embryos will give mostly older staged embryos, similar to those used for the immunostaining protocol. This will allow you to compare the two methods (Methods 2 and 4) for labeling proteins with a fluorescent tag. A brief collection of embryos during this or the previous lab period will give predominantly younger staged embryos. During the early stages of *Drosophila* development, nuclei are undergoing a rapid series of nuclear divisions. The GFP-tagged histones expressed in this stock may allow you to catch the dynamics of chromosome segregation in action.

Embryo Collection and Mounting Protocol

1. First prepare your microscope slide for mounting the embryos. Place two coverslips on top of it, spaced less than one width of a coverslip apart (as diagrammed to right). Transfer a drop of Halocarbon oil in the space between the two coverslips.

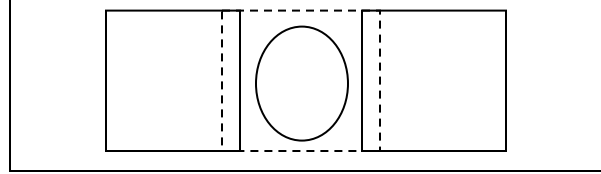

2. Each bench has been given two apple juice plates with *Drosophila* embryos. One plate (labeled wt) contains embryos lacking the GFP-tagged histone gene. The other contains embryos carrying the GFP-tagged gene. One lab group should collect from one plate, while the other collects from the other. You will collect the embryos from the plate as you did in the previous lab. Use the small brush and H₂O from your H₂O wash bottle to loosen the embryos from the surface of the plate.
3. Then pour the suspension of embryos into the minisieve in your Lab Bench Box. Be careful not to overfill the minisieve; pour a little at a time. Continue to rinse the plate with H₂O and pour the suspension into the sieve, until the bulk of the embryos have been transferred to the sieve.
4. Use the H₂O bottle to rinse the yeast paste (food for adult parents of the embryos) from the sieve. Place the sieve on a dry surface of a stack of paper towels to blot away excess H₂O.
5. Place the sieve with embryos in the petri dish cover. Use a Pasteur pipette and bulb to transfer Bleach into the sieve. Allow the bleach to fill the petri dish cover half-way. Gently rotate the petri dish cover to keep the embryos moving around in the Bleach for about 1 minute.
6. Transfer the sieve to a dry region of the stack of paper towels and immediately rinse with H₂O. Let the sieve fill with H₂O, and then move it to a new dry region of the paper towel stack. Repeat this procedure about 4 times, each time moving to a new dry area of the paper towel stack. The embryos will tend to aggregate together and flow to the center of the sieve.
7. Use the small paintbrush to lift the embryos from the surface of the sieve and transfer them to the drop of halocarbon oil. Place a coverslip on top of the embryos submerged in oil. The embryos are now ready to be viewed by standard light microscopy and fluorescence microscopy. **See Specimen Examination by Fluorescence Microscopy instructions below.**

Specimen Examination by Fluorescence Microscopy

1. Fluorescence microscopy requires a specialized high energy Mercury (Hg) light source. The Hg lamp is housed in the box next to your compound microscope. **The lamp should already be turned on. DO NOT TURN IT OFF.** You will first use standard light to visualize your specimen and bring it into focus (switch located on right side of microscope). Make sure the shutters between the Hg lamp and your specimen are closed while doing this. The levers for these shutters are located on top of your microscope (two pull levers pulled in and one dial lever turned towards C). **Because the live embryos are perishable, begin your observations with the live mount of wild type embryos. Start with the embryos from the stock expressing the GFP-tagged histone.** As always, begin with the lowest resolution objective and work your way up.
3. After you have brought the embryos into focus with standard light and the 10 x objective (**everything will appear uniformly non-fluorescent green (or blue), because the fluorescent filter cube is in place**), switch off the standard light and open all Hg lamp shutters. If the filter cube is not already in the green position (G), slide the filter cube positioning lever to bring it in position.

Are you able to see green **fluorescent** staining in your specimen? (#38)

Move the filter cube to the blue (B) filter position. Are you able to see blue fluorescent staining of your specimen? (#39)

What color was the beam of light projected onto the specimen at each position? Why was it different from the color of specimen staining? (#40)

5. A sketch of *Drosophila* embryos at various stages of development is shown in Figure 4. As shown in this figure, early staged embryos contain many fewer nuclei than later staged embryos. And later staged embryos contain multiple folds on their surfaces as a result of gastrulation (movement of groups of cells to form new tissues in the developing embryos). Use the stage positioning knobs to scan about the slide in search of both early and late staged embryos. Be particularly on the lookout for early staged embryos (stages 1-12), because these are undergoing the rapid nuclear divisions described above. You may be able to catch the dynamic process of chromosome segregation in action. In the later staged embryos, you may observe embryos in the process of gastrulation. You must be patient and diligent in looking for these dynamic events.

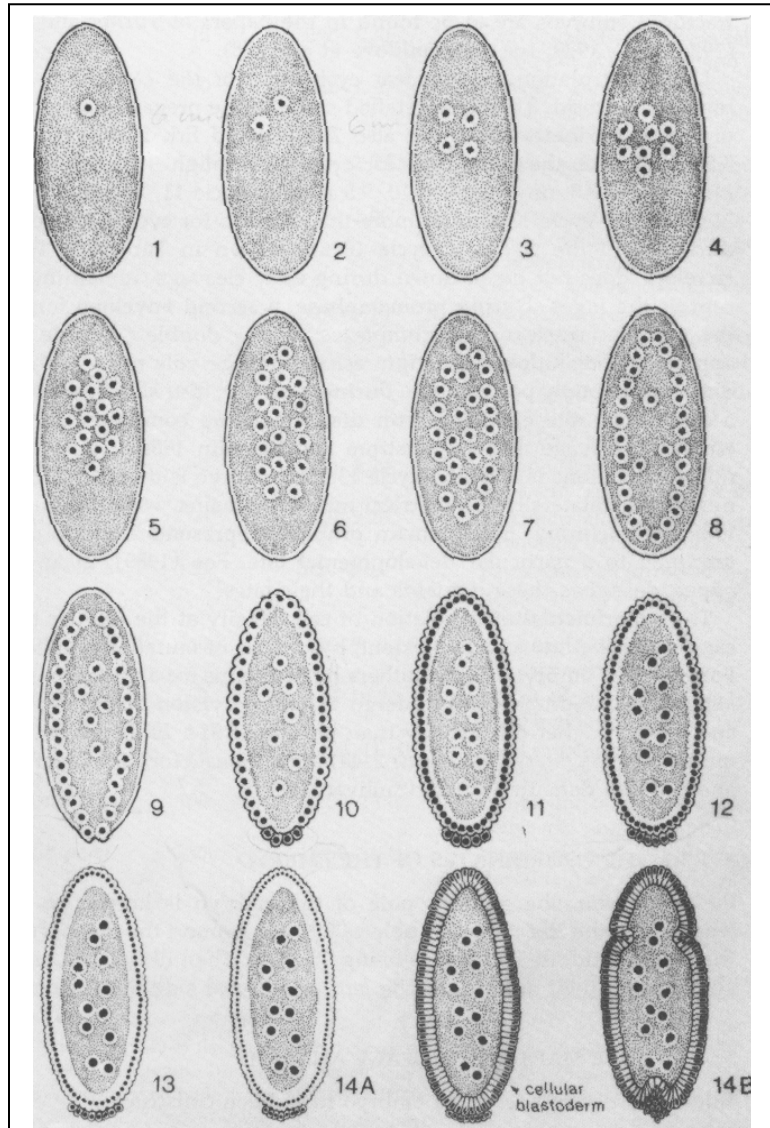

Figure 4. Sketches of *Drosophila* embryos at the first through fourteenth nuclear division cycle stage. The nuclei, represented as round structures within each embryo) undergo a rapid series of division before some of the nuclei migrate to the periphery of the embryo during nuclear division cycles 9-12. These nuclei are then surrounded by lipids to form the cellular blastoderm during nuclear cycle 14. The embryo then undergoes a series of cell migrations to form embryonic tissues in a process called gastrulation. FROM: *Drosophila A Laboratory Handbook*, Michael Ashburner ed., Cold Spring Harbor Laboratory Press, 1989.

5. Report what YOU observe in the space below. (**#41**)

6. Keeping the stage position as it is, now place the live mounting of the embryos from the wild type stock lacking the gene for GFP-tagged histone. Are YOU able to see green fluorescent staining in this specimen? (**#42**)

7. Keeping the stage position as it is, now place the **anti-histone immunostained embryo** specimen on the stage. Move the filter cube to the green (G) filter position (lever out). Are YOU able to see green **fluorescent** staining of in this specimen? (**#43**)

Move the filter cube to the blue (B) filter position (lever in). Are you able to see blue **fluorescent** staining of your specimen? (**#44**)

How does the anti-histone immunostaining pattern (Method #2) compare to the DAPI-staining pattern (Method #1)? How do you explain any differences or similarities? (**#45**)

8. Now, with the anti-neuronal immunostained sample, slide the filter cube to DAPI position (B) and bring the DAPI-stained nuclei into focus before moving the filter cube into the green (G) filter position to see the fluorescein-labeled anti-neuronal marker immunostaining pattern. Draw pictures of embryos at various stages of development as viewed with each filter and at both 10x and 40x. **(#46)**

How does this immunostaining pattern (Method #2) compare to the DAPI-staining pattern **(Method #1)**? How do you explain any differences or similarities? **(#47)**

Questions for Class Discussion:

1. Why might a researcher choose Method #3 or #4 over Method #1 or #2? **(#48)**
2. Can you think of any potential technical problems that might arise with GFP-tagging? **(#49)**

3. What specialized reagents would need to be made for Method #2? (#50)

4. When might a researcher choose Method #1 over Method #2? (#51)

5. What advantage did each of these methods give over the Iodine staining used to observe the squamous cheek cells in Lab 1A? (#52)

6. What specialized reagent would need to be made before you could do live imaging of a GFP-tagged protein? (#53)

Based on what you have learned about the advantages and disadvantages of each method which method would you choose for each of the following experiments and why:

1. You want to mark the position of the nucleus in fixed specimens that will be immunostained with a new antibody your lab has made against a protein of unknown function your lab has discovered. What method will you use to mark the nuclei and what can this experiment tell you about the newly discovered protein? (#54)

Name: _____ Section: _____

2. You want to observe the process of chromosome segregation in a mutant with a cell division defect. Which method would allow you to observe a chromosome segregation defect as it is happening (in the live mutant)? **(#55)**

3. You have discovered a new protein and want to know where it functions in the cell. Antibodies are very expensive to make, and your lab can't afford to make one. Can you think of a less expensive way to determine where your protein functions in the cell? **(#56)**

4. You try expressing a GFP-tagged version of your new protein, but expressing it in cells seems to kill the cells. You still can't afford to make an antibody against it. Is there another method that would allow you to determine where the protein functions in the cell? **(#57)**

5. Your lab advisor decided to go ahead and spend the money on making that antibody. You would love to compare its immunostaining pattern to that of another protein in the same cell. Can you think of a way to simultaneously immunostain for both proteins in a single sample and be able to tell the two apart? (Hint: Both antibodies need not be produced in the same species.) **(#58)**